



MUSTER 350

LIST OF THE EXPLODED VIEWS



SHELL ASSY

COOLING SYSTEM 2nd Version M350A - M350W - M350AW

COOLING SYSTEM 1st Version M350A/W - M350W

EVAPORATOR 2nd Version M350A - M350W - M350AW

EVAPORATOR 1st Version M350A/W - M350W

PUMP

ELECTRIC PARTS 2nd Version M350A - M350W - M350AW

ELECTRIC PARTS 1st Version M350A/W - M350W

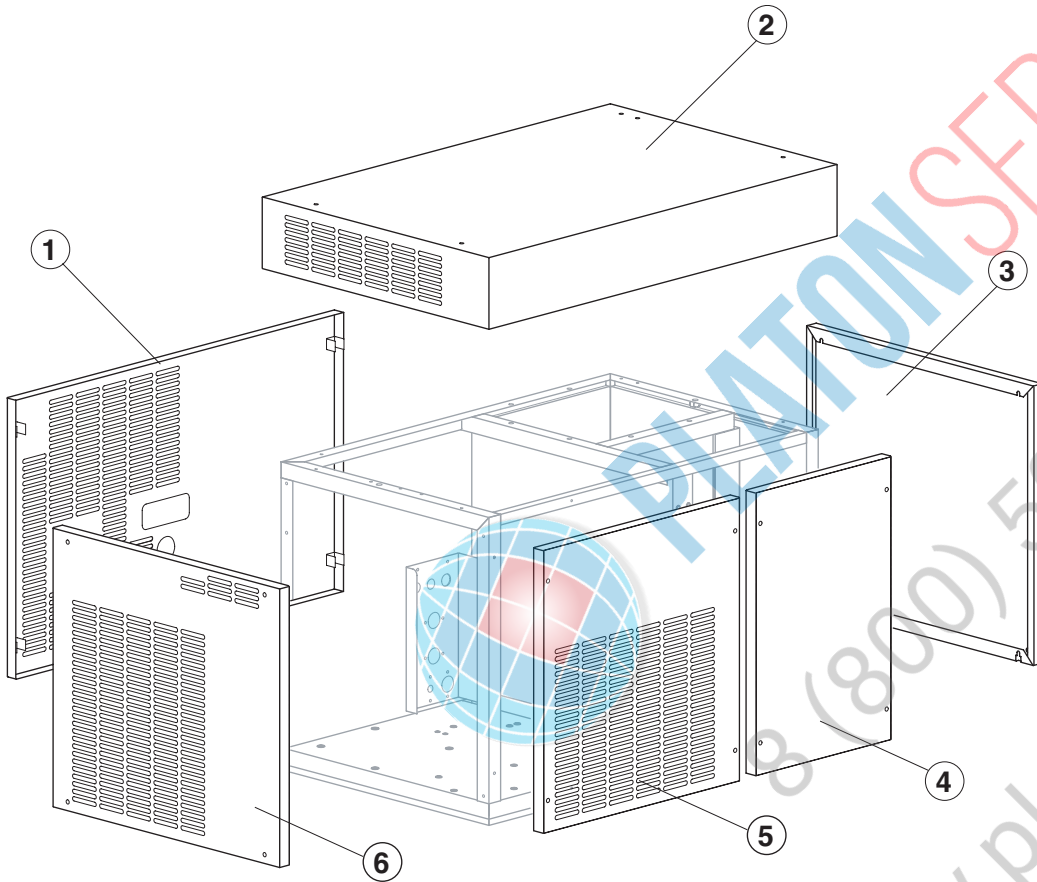

Ref.	Spare Description	Code
1	Rear Panel	22427
2	Top Assembly	C22422
3	Right Side Panel	22425
4	Front Panel Assy (Evaporator Side)	22424
5	Front Panel (Condenser Side)	C22423
6	Left Side Panel	22426

Rev. 11 - 14/02/2017



MUSTER 350

2nd Version M350A - M350W - M350AW

COOLING SYSTEM

Common Parts

Ref.	Spare Description	Code
1	Expansion Valve	20734
2	Orifice	Current Version 20943
2	Orifice	Till s/n. 471184 20797
7*	Solid Core Drier	14084
8*	Vacuum-Charge Valve Plug	14006
9*	Vacuum-Charge Valve Device	14005
10	Vacuum-Charge Valve Body	14007
11	Compressor	See Table -
12*	Hot Gas Valve Coil	23091
13*	Hot Gas Valve Body	20409

Parts for Air-Cooled Version Only

Ref.	Spare Description	Code
4	Sucking Fan	20407
5	Air Condenser	20670

Parts for Water-Cooled Version Only

Ref.	Spare Description	Code
3	Pressostatic Valve	20149
6	Water Condenser	14507

Parts for Mixed Cooled Version Only

Ref.	Spare Description	Code
4	Sucking Fan	20407
5	Air Condenser	20670
14	Water Condenser	14014

Ref. 10- Compressor

Voltage	Code
T11	23514
T12	23515
T15	23516
T16	23564

Rev. 11 - 14/02/2017

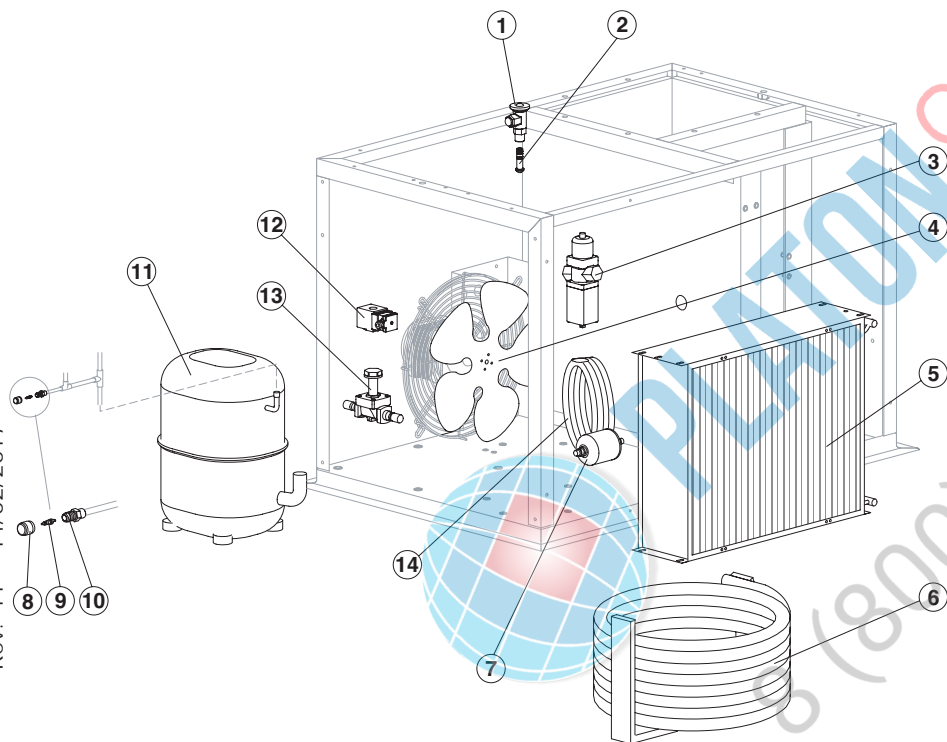

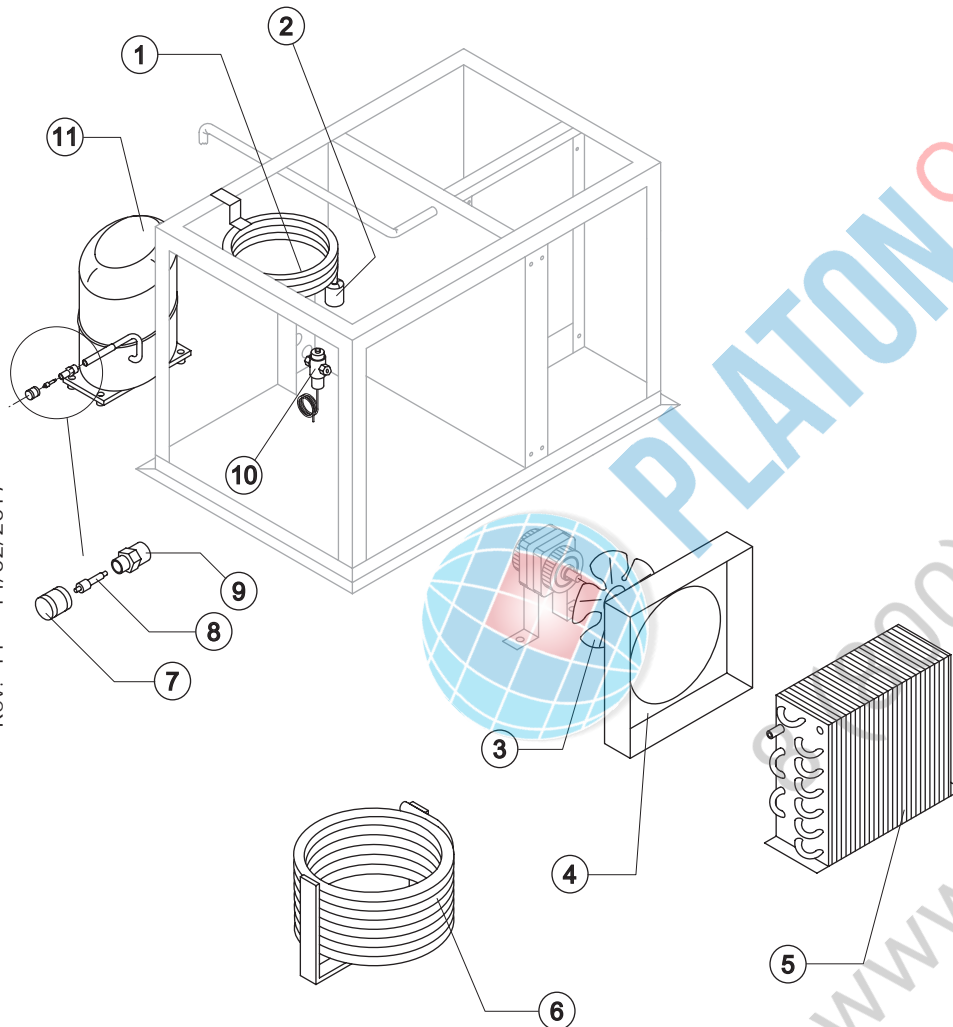

Common Parts

Ref.	Spare Description	Code
2	Solid Core Drier	14084
7	Vacuum-Charge Valve Plug	14006
8	Vacuum-Charge Valve Device	14005
9	Vacuum-Charge Valve Body	14007
10	Presostatic Valve	20149
11	Compressor	See Table -

Parts for Water-Cooled Version Only

Ref.	Spare Description	Code
3	Sucking Fan	20095
6	Water Condenser	14285

Parts for Mixed Cooled Version Only

Ref.	Spare Description	Code
1	Water Condenser	14014
3	Sucking Fan	20153
4	Conveyor	10238
5	Air Condenser	20651

Ref. 11- Compressor

Voltage	Code
T11	23514
T12	23515
T14	23564
T15	23516
T16	23564

Rev. 11 - 14/02/2017



MUSTER 350

2nd Version M350A - M350W - M350AW

EVAPORATOR

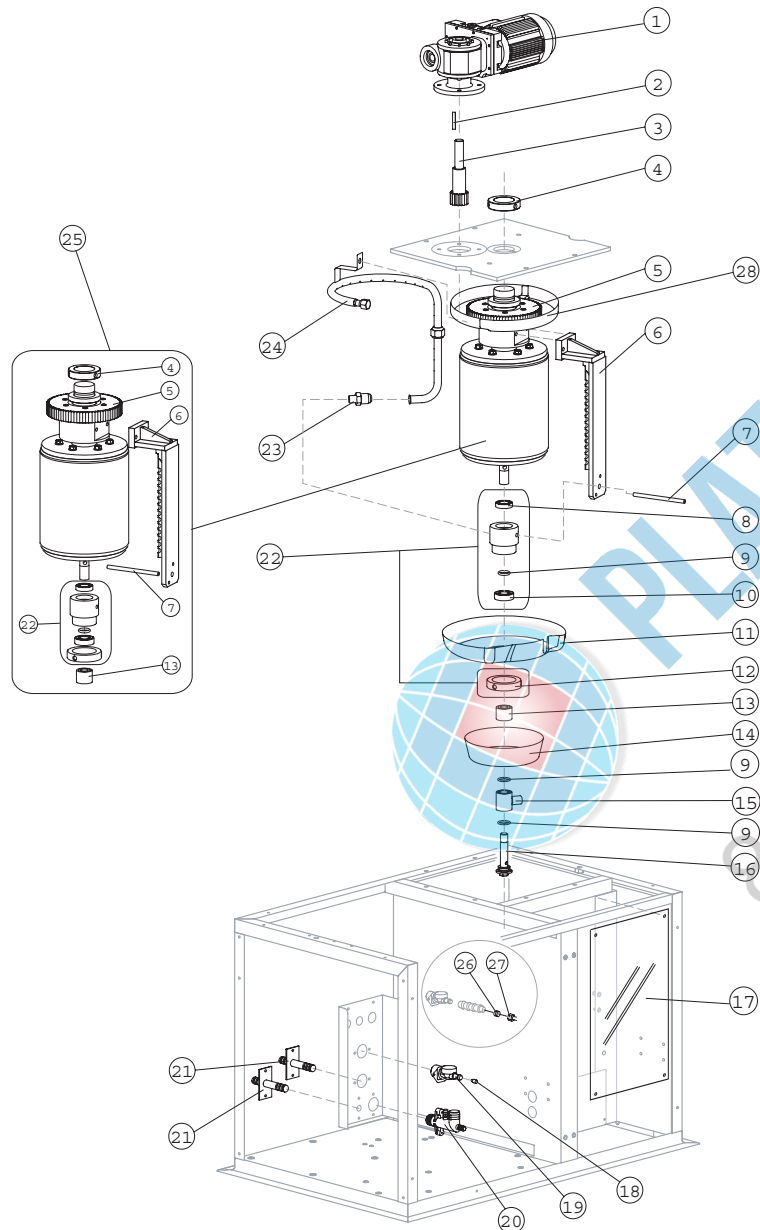

Common Parts

Ref.	Spare Description	Code
1	Gearmotor Assy	See Table
2	Key 6x6x40	20350
3	Pinion with Shaft for Gearmotor	C20344
4	Cylinder Locking Ring Nut	20324
5	Ring Gear	20354
6	Scraper	Current Version 20846
6	Scraper	Till s/n. 377385 20330
7	M8 Tie Rod (to Block Scraper)	20329
8	Stainless Steel Upper Bearing	20531
9	Silicone OR 4081 Ring	20338
10	Stainless Steel Bearing	20045
11	Rotating Basin	10184
12	Ring Nut for Rotating Ring	10182
13	Spacer	Current Version 10519
13	Spacer	Till s/n. 377385 20321
14	Fixed Basin	C10598
15	Water Inlet Ring	20851
16	Screw	20849
17	Evaporator Chamber Shield	Current Version 10523
17	Evaporator Chamber Shield	Till s/n. 377385 10187
19	1 Way- Water Inlet Nipple	10239
20	Discharges Manifold	10580
22	Complete Rotating Ring	C10180
23	Joint	20335
24	Sprayer Ring	C20858
24	Sprayer Ring	Till s/n. 377385 C20319
25	Evaporator	Current Version C20844
25	Evaporator	Till s/n. 377385 KITNEVM350
26	Bush	Till s/n. 261851 20405
27	Nut	Till s/n. 261851 20404
28	Ring Gear Cover	From s/n. 551986 C10629

Parts for Mixed Cooled Version Only

Ref.	Spare Description	Code
18	Lt. 1,2 Flow Control for Water Inlet Connector	10011
21	Connection with Plate	C20462

Parts for Water-Cooled Version Only

Ref.	Spare Description	Code
21	Connection with Plate	C20462

Ref. 1- Gearmotor assy

Voltage	Code
T11-T15	C23412
T12-T16	C23389

Rev. 11 - 14/02/2017



MUSTER 350

1st Version M350A/W - M350W

EVAPORATOR

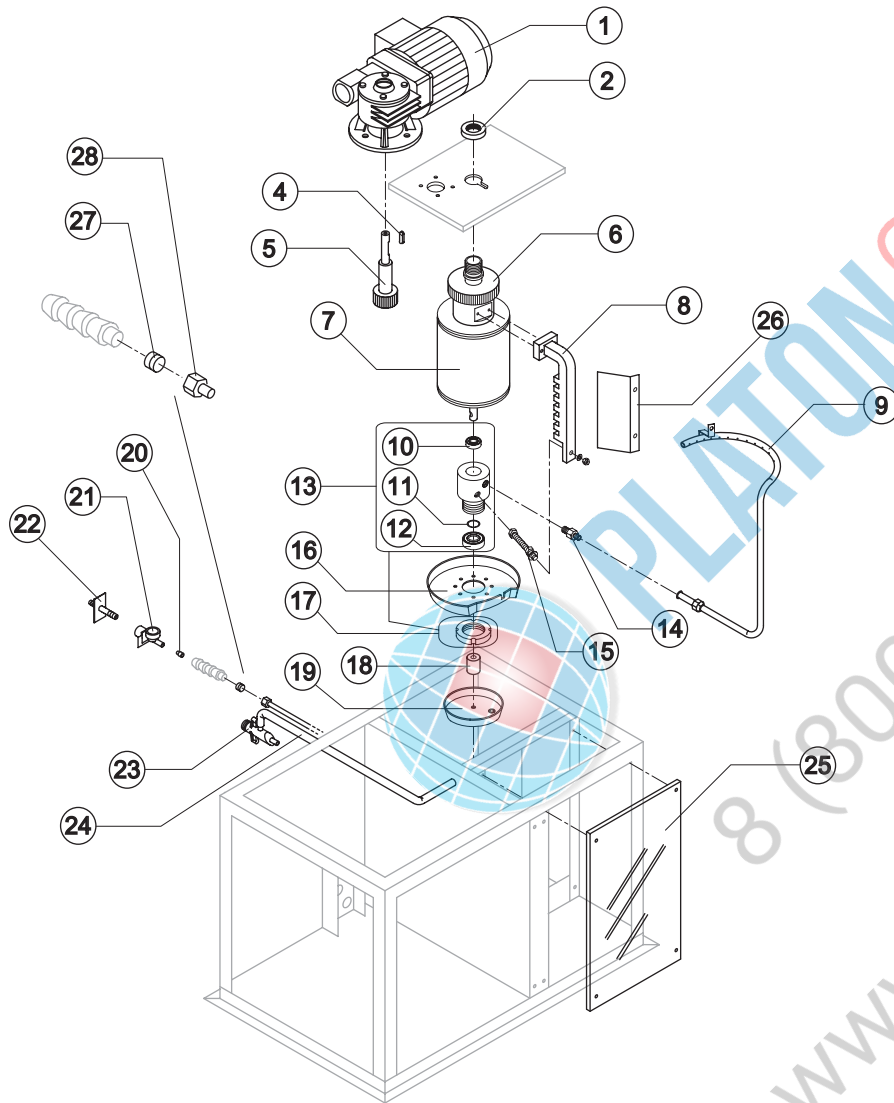

Common Parts

Ref.	Spare Description	Code
1	Gearmotor Assy	C23389
2	Cylinder Locking Ring Nut	20324
4	Key 6x6x40	20350
5	Pinion with Shaft for Gearmotor	C20344
6	Ring Gear	20354
7	Evaporator	KITNEVM350
8	Scraper	20330
9	Sprayer Ring	C20319
10	Stainless Steel Upper Bearing	20531
11	Silicone OR 4081 Ring	20338
12	Stainless Steel Bearing	20045
13	Complete Rotating Ring	C10180
14	Joint	20335
15	M8 Tie Rod (to Block Scraper)	20329
16	Rotating Basin	10184
17	Ring Nut for Rotating Ring	10182
18	Spacer	20321
19	Fixed Basin	C10185
21	1 Way- Water Inlet Nipple	10239
24	Overflow Pipe	13082
25	Evaporator Chamber Shield	10187
26	Baffle Plate	10421
27	Bush	20405
28	Nut	20404

Parts for Air-Cooled Version Only

Ref.	Spare Description	Code
22	Connection with Plate	C20462
23	Discharges Manifold	10579

Parts for Mixed Cooled Version Only

Ref.	Spare Description	Code
20	Lt. 1,2 Flow Control for Water Inlet Connector	10011
23	Discharges Manifold	C10053

Rev. 11 - 14/02/2017



MUSTER 350

2nd Version M350A - M350W - M350A/W
 1st Version M350A/W - M350W

PUMP

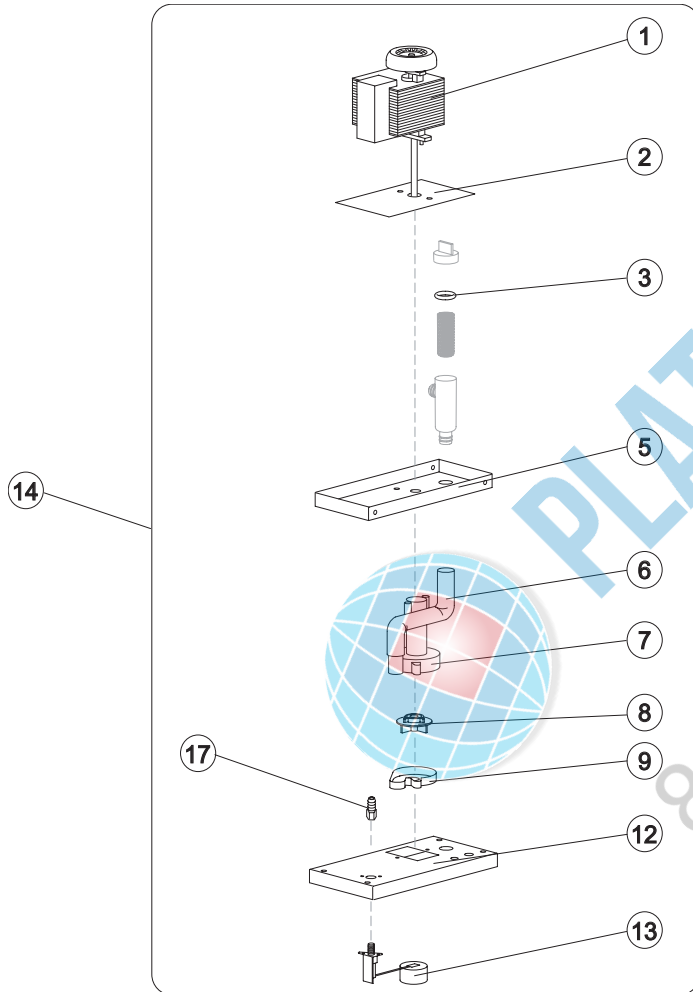

Ref.	Spare Description	Code
1	Pump	See Table -
2	Heat Dissipator	22430
3	Pump Filter Gasket	13080
5	Pump Motor Support	10161
6	Pump-Filter Connection Pipe	13084
7	Pump Body	10065
8	Pump Impeller	10190
9	Diffusor	10067
12	Water Pump Basin Cover	22420
13*	Floating Valve	10188
14*	Pump and Filter Assy	See Table -
17	Connection	20799

Ref. 1 - Pump Motor

Voltage	Code
T11	23073
T12	23187
T14	23073
T15	23073
T16	23187

Ref. 14* - Pump and Filter Assy

Voltage	Code	Till s/n. 377385
T11	C26736	C26557
T12	C26737	C26713
T14	C26736	C26557
T15	C26736	C26557
T16	C26737	C26713

Rev. 11 - 14/02/2017



MUSTER 350

2nd Version M350A - M350W - M350AW

ELECTRIC PARTS

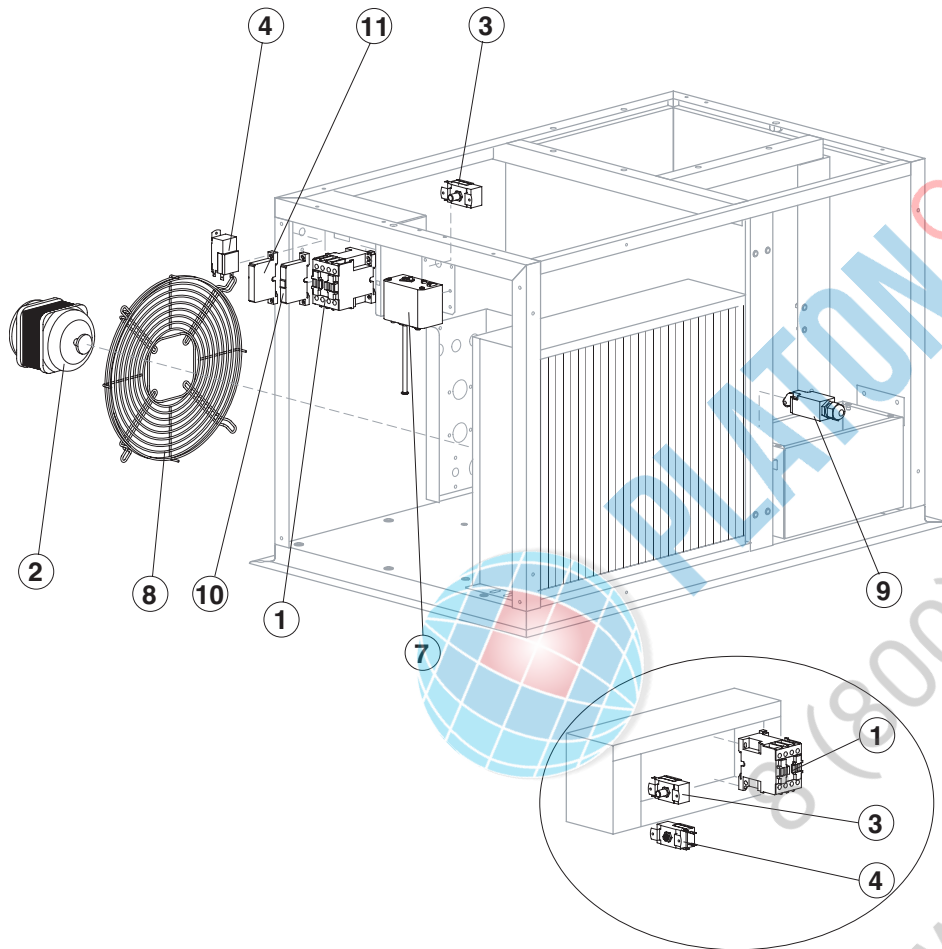

Common Parts

Ref.	Spare Description	Code
1*	Contactor	See Table
3	Safety Pressure Switch (Maximum Pressure)	23342
4*	Bin Thermostat	R23005
7	Safety Pressure Switch (Minimum Pressure)	23763
9	Microswitch for Overflow Ice	23746
10	Thermomagnetic circuit breaker	23910
11	Electronic Delay Timer	From s/n. 515704 231033

Parts for Air-Cooled and Mixed Cooled Version Only

Ref.	Spare Description	Code
2*	Fan Motor	23121
8	Fan Motor Grid	12056

Ref. 1*- Contactor

Voltage	Code
T11	23147
T12	23963
T15	23147
T16	23963

Rev. 11 - 14/02/2017



Common Parts

Ref.	Spare Description	Code
1	Relay	23190
2	Anti Radio Interference Filter T11 and T15	C23458
3	Contactor	See Table
5	Safety Pressure Switch (Maximum Pressure)	23342
7	Safety Thermostat	R23447
8	Bin Thermostat	R23421
10	Microswitch for Overflow Ice	R23373

Parts for Water-Cooled Version Only

Ref.	Spare Description	Code
4	Fan Motor	23029

Parts for Mixed Cooled Version Only

Ref.	Spare Description	Code
4	Fan Motor	23121
6	Condenser Pressure Switch	23175
9	Anti Radio Interference Filter T11 and T15	C23459

Ref. 3- Contactor

Voltage	Code
T11	23147
T12	23963
T14	23147
T15	23147
T16	23963

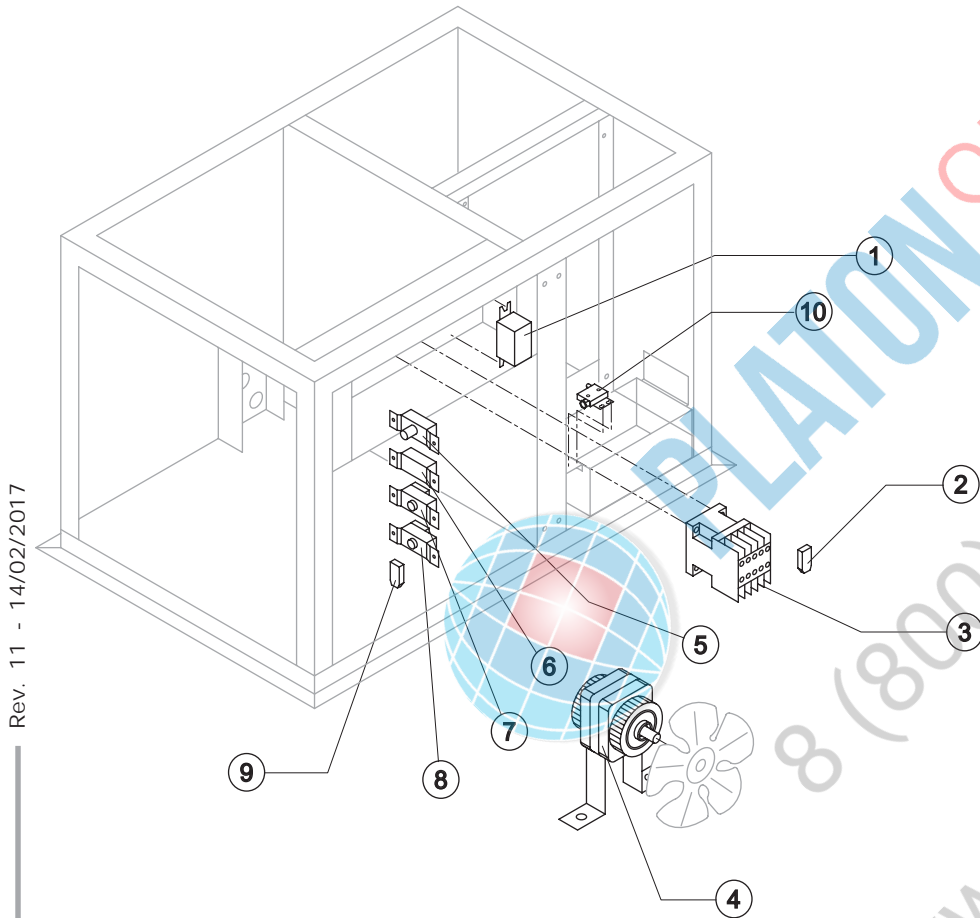

Rev. 11 - 14/02/2017